

CXDI-50C Specifications

Purpose	General radiography
Method	Flat panel detector: scintillator & amorphous silicon (a-Si)
Sensor	LANMIT 7 (Large Area New-MIS sensor and TFT)
Scintillator	CsI (Cesium Iodide):Tl
Pixel pitch	160 x 160 microns
Pixels	2,208 x 2,688 pixels (5.9 million pixels)
Image size	Automatic sizing up to 35 x 43 cm (14 x 17 in.)
A/D	14-bit
Grayscale	4,096 grayscale (12-bit)
Preview image access time*	Approx. 3 – 5 seconds after X-ray exposure
Interface	DICOM 3.0, Ethernet 10/100 Base T
DICOM*	DICOM 3.0 compatible, Print Management Service Class (SCU), Storage Service Class (SCU), and others
Voltage	100V, 120V, 230/240V (50/60Hz)
Power consumption	Sensor unit: 200VA maximum
Operating environment	Sensor unit: 5 – 35° (41 – 95°F) 30 – 75% RH (non-condensing)
Certification	FDA 510(k), FCC Class A, UL 2601-1, EN60601, CE0197
Dimensions	Sensor unit (W x L x T): 491 x 477 x 23 mm (19.3 x 18.8 x 0.9 in.)
Weight	Sensor unit: 4.8 kg (10.6 lb.)
Standard components	Sensor unit, power box, remote switch, x-ray interface cable

*Actual times may differ due to various factors. **Varies with system configuration.

■ User Options

Grid	Choice of 10:1 (180 cm), 6:1 (150 cm), 8:1, 4:1 (110 cm)
Software options	Please contact an authorized Canon dealer.

LANMIX LANMIX is a new name that represents the total solution offered by Canon, through the combination of our LANMIT (Large Area New-MIS Sensor and TFT) detector and other X-ray imaging equipment and software. In the future, expect more great systems from Canon under this new name.

Specifications are subject to change without notice.

Names of companies or products appearing in this document are trademarks and/or registered trademarks of their respective owners.

Canon

CANON MEDICAL SYSTEMS
A division of Canon Canada Ltd.
6390 Dixie Road
Mississauga, Ontario
L5T 1P7

Please contact us at:
Telephone: (905) 795-1111
Medical_Systems@canada.canon.com
www.canon.ca

© 2009 Canon Canada Inc. All rights reserved.
Printed on the Canon imagePress™ C7000VP
imagePRESS is a trademark of Canon Inc.



Printed on Recycle paper in Canada

Canon



Digital Radiography System

CXDI-50C

Premium Portable Flat Panel Detector

High Sensitivity, High Resolution Portable DR Imaging

With a large imaging area, superb dose efficiency, and a lightweight design, the portable CXDI-50C extends Digital Radiography to a greater range of exams than ever before.



A Revolutionary Portable DR Solution Providing Unmatched Efficiency, Effectiveness, and Versatility

Discover the CXDI-50C, a portable, lightweight DR system that provides fast, high quality, filmless image capture for a wide range of radiographic applications. Featuring Canon's advanced flat panel detector technology with an incorporated Cesium Iodide scintillator for higher X-ray absorption, the highly sensitive system delivers better images, faster, and with lower X-ray doses than conventionally required.

Portable, Lightweight Design

Less than an inch thick (23 mm) and weighing only 4.8 kg (10.6 lb.), the compact CXDI-50C can be flexibly used in diverse applications, including trauma, ICU, and bedside exams. It's portable, lightweight, and easy to position—even the patient can comfortably hold the unit in place during image capture, if necessary.



Easy-carry ergonomic design, weighs just 4.8 kg (10.6 lb.)

Large Imaging Area

The CXDI-50C features a large 35 x 43 cm (14 x 17 in.) imaging area to capture detailed X-rays from virtually any position and angle. From examinations of the skull, spine, chest, abdomen, to the extremities, the generous size of the detector accommodates a wide variety of exams.

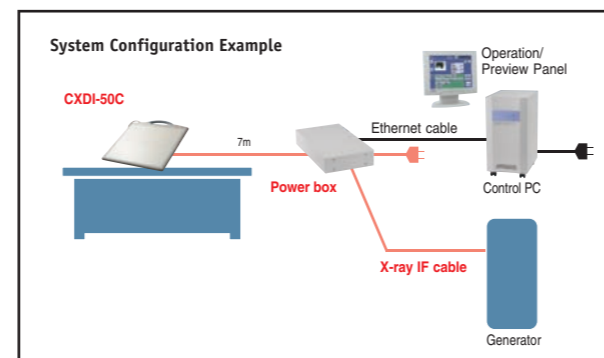

Superior Diagnostic Image Quality

The core component of the CXDI-50C is Canon's Amorphous Silicon (a-Si) Flat Panel Detector with Cesium Iodide (CsI) scintillator, which produces clear, high-resolution diagnostic images in 12-bit grayscale (4,096 gradations). The highly sensitive 5.9-million pixel detector features an expansive 104 dynamic range to capture subtle contrast and fine image detail that would otherwise appear over or underexposed on conventional film.

Immediate Results

Preview images are available just seconds after exposure, allowing for immediate image confirmation and network transfer. And the detector is ready for the next X-ray exposure just moments later thanks to a fast refresh cycle.

Extensive Network Capabilities

Ethernet 10/100 Base T connectivity with DICOM 3.0 compatibility enables seamless data transfer to any DICOM hard copy output device, PACS, or RIS for efficient printing, archiving, and remote viewing of images.



Highly sensitive for superb dose efficiency

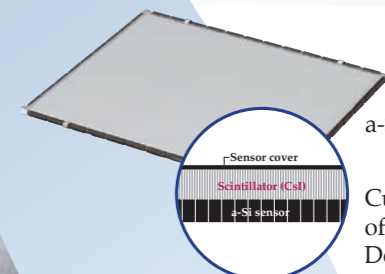

a-Si Flat Panel Detector

Cutaway diagram of a-Si Flat Panel Detector layers

Gentler on patients than conventional DR systems

Featuring Canon's advanced LANMIT 7 detector technology, the CXDI-50C efficiently delivers high-quality diagnostic images with minimal X-ray exposure to patients, making it ideal for pediatric and orthopedic use. The Amorphous Silicon Flat Panel Detector of the CXDI-50C is coated with a scintillator made of an array of tiny Cesium Iodide (CsI) crystals, which offers the dual benefits of more effective X-ray absorption and higher signal-to-noise performance compared with conventional systems.

